

A Novel Inter Connection of DFIG with Grid in Separate Excitation SMES System with Fuzzy Logic Control

A Kavitha^{*1}, AV Suresh²

Dept. of Electrical & Electronics Engineering, QIS Institute of Technology, Andhra Pradesh, India

*Corresponding author, email: chandra.qisit@gmail.com

Abstract

The use of doubly fed induction generators (DFIGs) in wind turbines has become quite common over the last few years. DFIG wind turbine is an integrated part of distributed generation system. This paper presents a Fuzzy based controller SMES unit in DFIG for improving the ac output on grid side. The excitation system is composed of the rotor-side converter, the grid-side converter, the dc chopper and the superconducting magnet. The superconducting magnet is connected with the dc side of the two converters, which can handle the active power transfer with the rotor of DFIG and the power grid independently, even though small fluctuations occur in active power on AC side. For smoothing the AC output power waveform a Fuzzy based controller is introduced in SMES controller unit, which is implemented using simulation developed in MATLAB/ SIMULINK 7.2 version. The model of the FUZZY controlled SMES based excitation system for DFIG is established, and the simulation tests are performed to evaluate the system performance.

Keywords: Doubly-fed induction generator (DFIG), superconducting magnet energy storage (SMES), wind power generation, FUZZY controller

1. Introduction

The Figure 1 shows the main components of a wind power system [1].

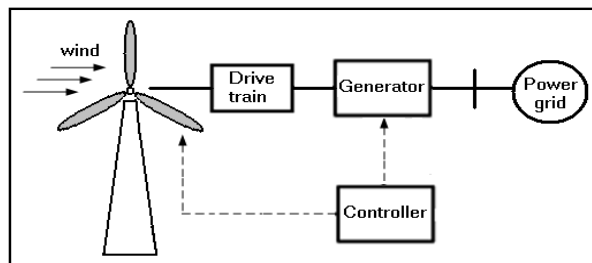

Figure 1. A Wind Power System and its Main Components

The main components of this system are the wind turbine, the mechanical drive train, the generator, the power grid, and the controller. The wind turbine converts the kinetic energy of the wind into mechanical energy [2-5]. The generator converts the mechanical energy into electrical energy. The controller is the “brain” of the system. It ensures that the whole system works as expected.

The mechanical power P_{mech} is extracted from the wind. The following formula describes P_{mech}

$$P_{mech} = 0.5 \rho \pi R^2 v^3 C_p(\lambda, \theta) \quad (1)$$

where

P_{mech} is the mechanical power ρ is the air density,

R is the turbine's radius v is the wind speed,
 C_p is the power coefficient λ is the tip speed ratio and Θ is the pitch angle.
 λ is defined as:

$$\lambda = \omega_m R/v \quad (2)$$

where ω_m is the turbine rotation speed,
 R is the turbine's radius,
 v is the wind speed.

The extracted mechanical power P_{mech} is proportional to the cube of the wind speed v . The power coefficient C_p affect P_{mech} . C_p is a function of the tip speed ratio λ and of the pitch angle Θ . λ describes the ratio between the system rotational speed ω_m and v . Θ is the angle between the wind flow direction and the turbine blade. Increasing Θ moves the blades out of the wind, thereby reducing the effective wind area [6-7].

In this Figure 2, the blue lines are the power coefficients depending on Θ and λ . Physically, the greater the pitch angle, the smaller the effective wind area. On figure 2 you can see that as a consequence, the greater the pitch angle, the smaller the power coefficient. For one particular pitch angle, there exists an optimal tip speed ratio that maximizes the power coefficient C_p . The red dot in figure 2 corresponds to the optimal wind energy utilization point. To better utilize wind energy it is desirable to operate the turbine at its most efficient point. In the previous figure, the red circle represents the point at which the turbine operates most efficiently.

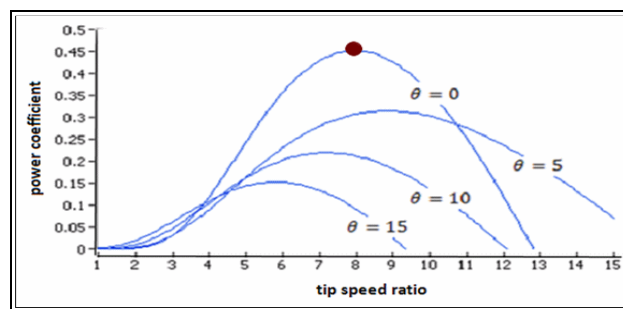

Figure 2. C_p as a Function of the Pitch Angle Θ and of the Tip Speed Ratio λ

2. Doubly-FED Induction Generator Based Wind Turbine System and SMES Unit

The DFIG-based wind turbine system is one of the main variable-speed wind power systems. Nowadays, variable speed wind turbines with a DFIG directly connected to the grid are widely used in the field. For the dynamic feature, the DFIG becomes the most popular generator for wind power generation system. Firstly, DFIG can supply power to the grid at constant voltage and constant frequency while the rotor can operate at sub-synchronous mode or super-synchronous mode. Secondly, the rating of the power converter is only about 30% of the rated power of the wind turbine [8-10]. At third, the generated active and reactive power can be controlled independently with wind speed variation. Figure 3 displays its system diagram. In Figure 3:

- P_{mech} is the extracted mechanical power
- P_{total} is the total generated electrical power
- P_s is the power from the stator to the grid
- P_r is the power from the rotor to the grid
- ω_r is the rotor rotational speed
- ω_s is the synchronous speed

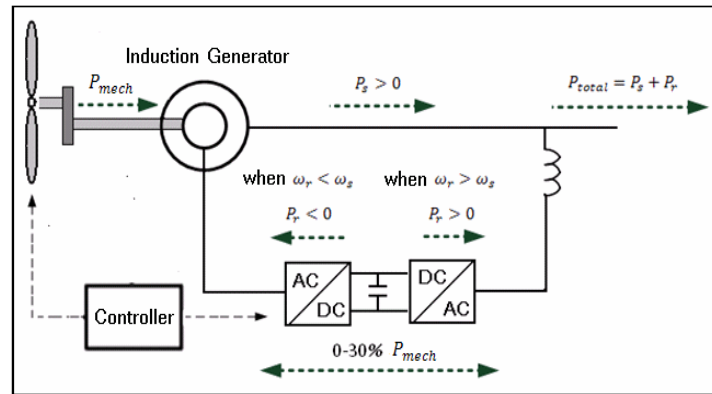

Figure 3. System Diagram of a DFIG-Based Wind Turbine System

One characteristic of the DFIG-based wind turbine system is the bidirectional power flow of the rotor. When $\omega_r > \omega_s$, the power flows from the rotor to the power grid. When $\omega_r < \omega_s$, the rotor absorbs the energy from the power grid. Similar to a traditional power system, the stator of the generator directly connects to the power grid. Unlike in the traditional power system, the rotor of the generator connects to the power grid through power electronic converters. So in this system, the energy is delivered to the power grid not only by the stator, but also by the rotor. Hence, this system is called “doubly-fed”. These power electronic converters adjust the frequency and amplitude of the rotor voltage. The control of the rotor voltage allows this system to operate at a variable-speed while still producing constant frequency electricity [11-13].

The excitation system is composed of the rotor-side converter, the grid-side converter, the dc chopper and the superconducting magnet. The superconducting magnet is connected with the dc side of the two converters, which can handle the active power transfer with the rotor of DFIG and the power grid independently. Utilizing the characteristic of high efficient energy storage and quick response of super conducting magnet, the system can be utilized to level the wind power fluctuation, alleviate the influence on power quality, and improve fault ride-through capability for the grid-connected wind farms. According to the system control objective, the system can contribute to the stability and reliability of the wind power grid-connected system [2, 14].

The DFIG is equipped with a back-to-back power electronic converter, which can adjust the generator speed with the variety of wind speed. The converter is connected to the rotor windings, which acts as AC excitation system. The converter is much cheaper, as the rating is typically 25% of total system power, while the speed range of the generator is 33% around the synchronous speed. Although the DFIG have good performance, there are some issues should be concerned when the wind farms with DFIGs are widely connected to the power grid. The first issue is the power quality induced by the fluctuant power. Taking into account the amplification factor of the inverse slip ratio of the doubly-fed machine, the regulation capability of the DFIG is limited, especially in the condition of frequent wind speed variation [5].

The second issue is the operation of DFIG during grid faults. Faults in the power system, even far away from the location of the turbine, can cause a voltage dip at the connection point of the wind turbine. The dip in the grid voltage will result in an increase of the current in the stator windings of the DFIG, which will induce the over current in the rotor circuit and the power electronic converter. With the increasing of grid-connected wind farms, the fault ride-through capability is demanded for DFIG to decrease the adverse effect on the stability of power system. To solve the above problems, the energy storage unit is a preferred way to handle the energy transfer caused by power fluctuation or grid fault. An integrated power generation and energy storage system for doubly-fed induction generator based wind turbine systems is proposed. Superconducting magnetic energy storage (SMES), which is characterized by its highly efficient energy storage, quick response, and power controllability, is introduced to the DC link of the back-to-back power converters of the DFIG through a bi-directional DC/DC power electronic converter [13-14]. The SMES is controlled to level the wind

power fluctuation alleviate the influence on power quality, and improve fault ride-through capability for the grid-connected wind farms. Using MATLAB SIMULINK, the model of the SMES based excitation system for DFIG is established as Table 1, and the simulation tests are performed to evaluate the system performance.

a) Superconducting Magnetic Energy Storage (SMES)

The combination of the three fundamental principles (current with no restrictive losses; magnetic fields; and energy storage in a magnetic field) provides the potential for the highly efficient storage of electrical energy in a superconducting coil. Operationally SMES is different from other storage technologies in that a continuously circulating current within the superconducting coil produces the stored energy. In addition, the only conversion process in the SMES system is from AC to DC. As a result, there are none of the inherent thermodynamic losses associated with conversion of one type of energy to another (EPRI, 2002).

SMES systems have the following parts - superconducting coil, power conditioning system, cryogenically cooled refrigerator, cryostatic vacuum vessel. In an SMES system, because the electrical current has zero resistance, the magnetic field once created will almost never be weakened unless the system breaks itself. So, compared to other systems, it loses the least amount of energy during storage making them very efficient. They are also highly reliable because major components in SMES are motionless. The most important feature of SMES is that the time it takes to charge and discharge is very short. Right now, SMES systems are mainly used to improve power quality.

The individual, trailer-mounted Distributed-SMES units consist of a magnet that contains 3 MJ of stored energy as Figure 4.

TABLE I
DESIGN PARAMETERS

Item	Parameters	
DFIG	Rating power	75 kW
	Rating voltage	380 V
	Stator leakage reactance	4 mH
	Rotor leakage reactance	2 mH
	mutual inductance	69.31 mH
Rotor-side converter	rating power	25 kVA
	Switching frequency	5 kHz
Grid-side converter	rating power	45 kVA
	Filter inductor L	6 mH
	Switching frequency	5 kHz
DC chopper	rating power	80 kVA
	Switching frequency	10 kHz
	DC link capacitor	9400 μF
	DC rating voltage	600 V

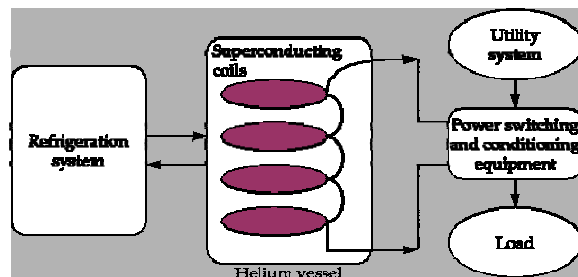

Figure 4. Is an illustration of a commercially produced SMES product

b) The Principles of Superconducting Magnetic Energy Storage

Energy stored in a normal inductor will fade out rather quickly due to the ohmic resistance in the coil when the power supply is disconnected. Obviously this will not be an acceptable energy storage for use in a power system. The ohmic resistance has to be removed before an inductor can work for this purpose. This is possible by lowering the temperature of the conductors, and by this making the conductors superconducting. A superconducting wire is in a state where the resistance in the material is zero. In this state the current in a coil can flow for infinite time. This can also be seen from the time constant of a coil $\tau = \frac{L}{R}$ Where R goes to zero and τ then goes to infinity. There are constraints for a superconducting wire to stay superconducting. The conductor has to be operated below a critical temperature T_c , below a

critical current I_c and below a critical magnetic field H_c . There should also be some safety margin between the critical values and the operating conditions.

3. Control Strategies

The control system establishes a link between power demands from the grid and power flow to and from the SMES coil. It receives dispatch signals from the power grid and status information from the SMES coil. The integration of the dispatch request and charge level determines the response of the SMES unit. The control system also measures the condition of the SMES coil, the refrigerator, and other equipment. It maintains system safety and sends system status information to the operator. Modern SMES systems are tied to the Internet to provide remote observation and control. The overall efficiency of SMES is in the region of 90% to 99%. SMES has very fast discharge times, but only for very short periods of time, usually taking less than one minute for a full discharge. The Conventional control circuit for SMES is shown in Figure 5.

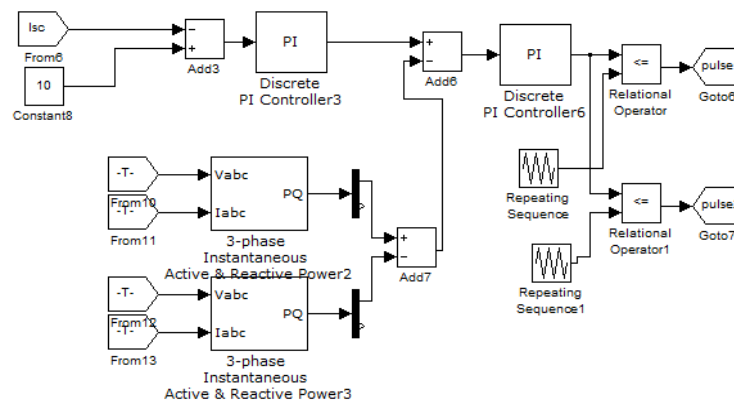

Figure 5. MAT LAB based Conventional control circuit for SMES

a) Block Diagram of Control System in SMES based DFIG system.

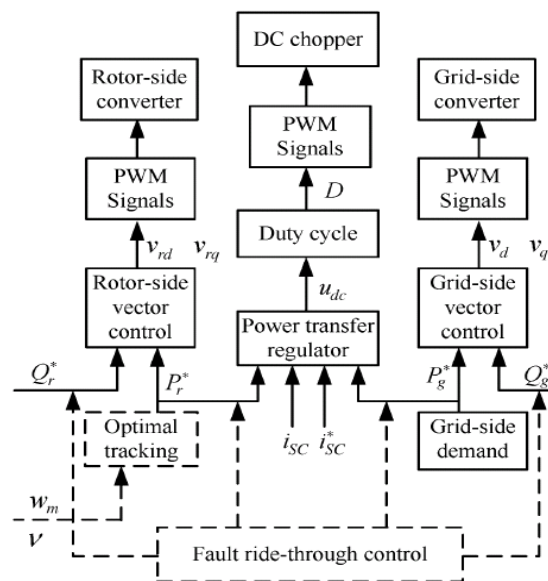

Figure 6. Control diagram of the SMES based DFIG system.

The system control is composed of two levels. Firstly, the operation state of the wind turbine and the grid is monitored. Based on the operation data, the power demand of the rotor-side and grid-side can be analyzed. This function can be regarded as the system level. Then, the other is equipment level, which includes the rotor-side converter control, the grid-side converter control and the DC chopper control. The equipment level respond to the power demand of the system level, and control the DFIG to fulfill different functions. The basic control diagram is shown in Figure 6.

b) The System Level

The system level control can be divided into two conditions. In normal operation state of the grid, the DFIG can realize the operation of VSCF based on tracking the wind speed. In the condition of grid fault, the control objective is to reduce the adverse effect from the grid side and improve the ride-through capability of the DFIG. This control level gives out the power demand for the converters and the SMES, which is represented as the dash line in the Figure 6.

3. Matlab Design of Case Study and Results

The DFIG rotor side, stator side and smes side control circuits in MATLAB are shown in sequentially

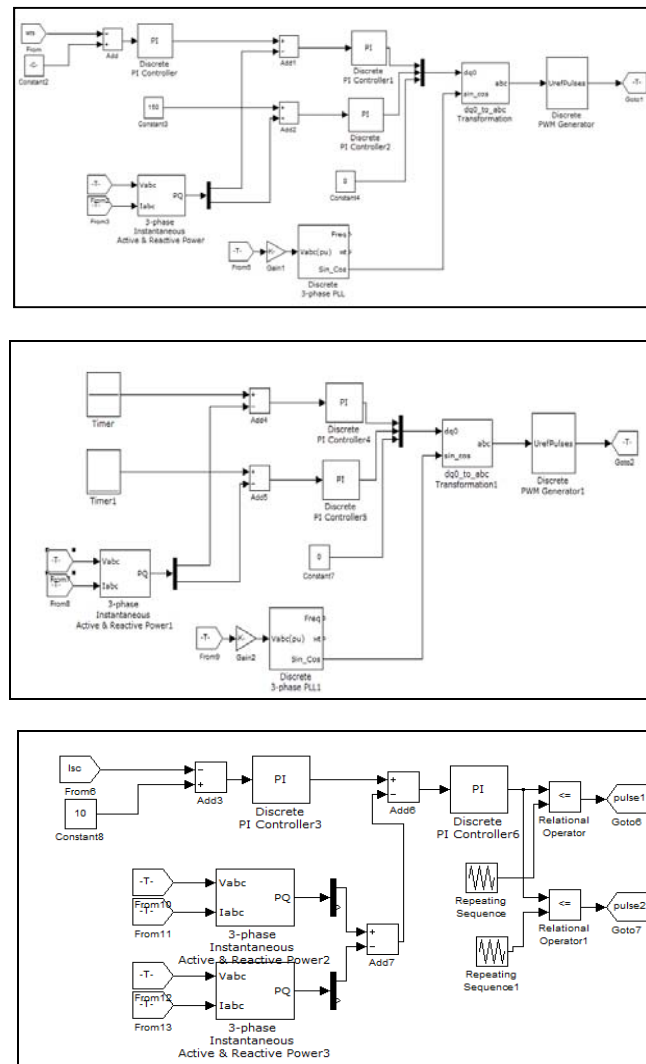

Figure 7. Control circuits of rotor side, grid side converters and conventional control circuit for SMES

The MATLAB based DFIG circuit and rotor side, stator side and SMES side output wave forms are explained below

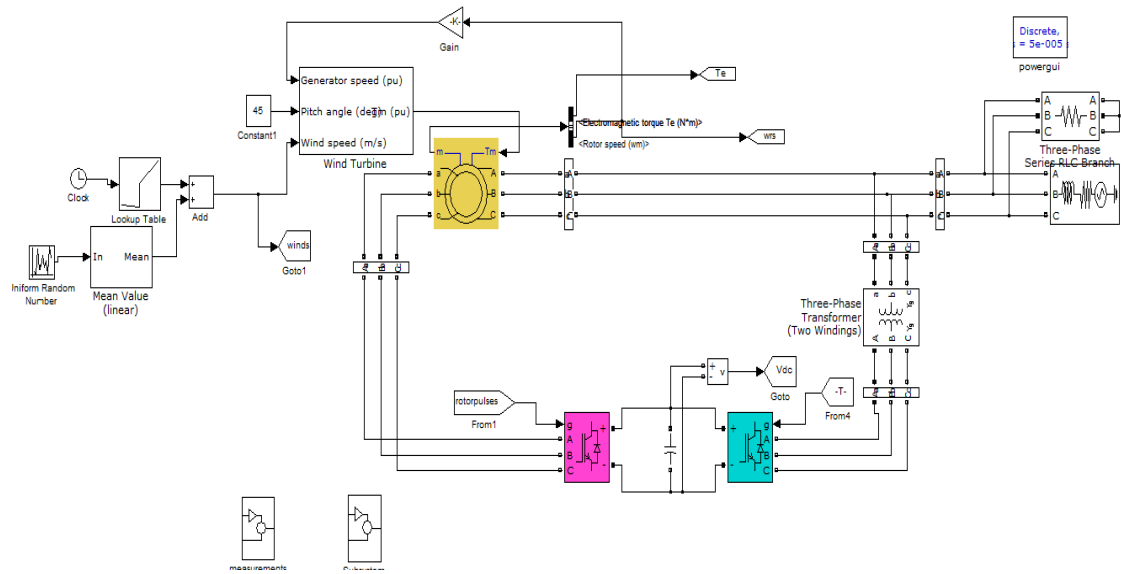

Figure 8. MAT Lab based circuit of DFIG Wind Power System without SEMS

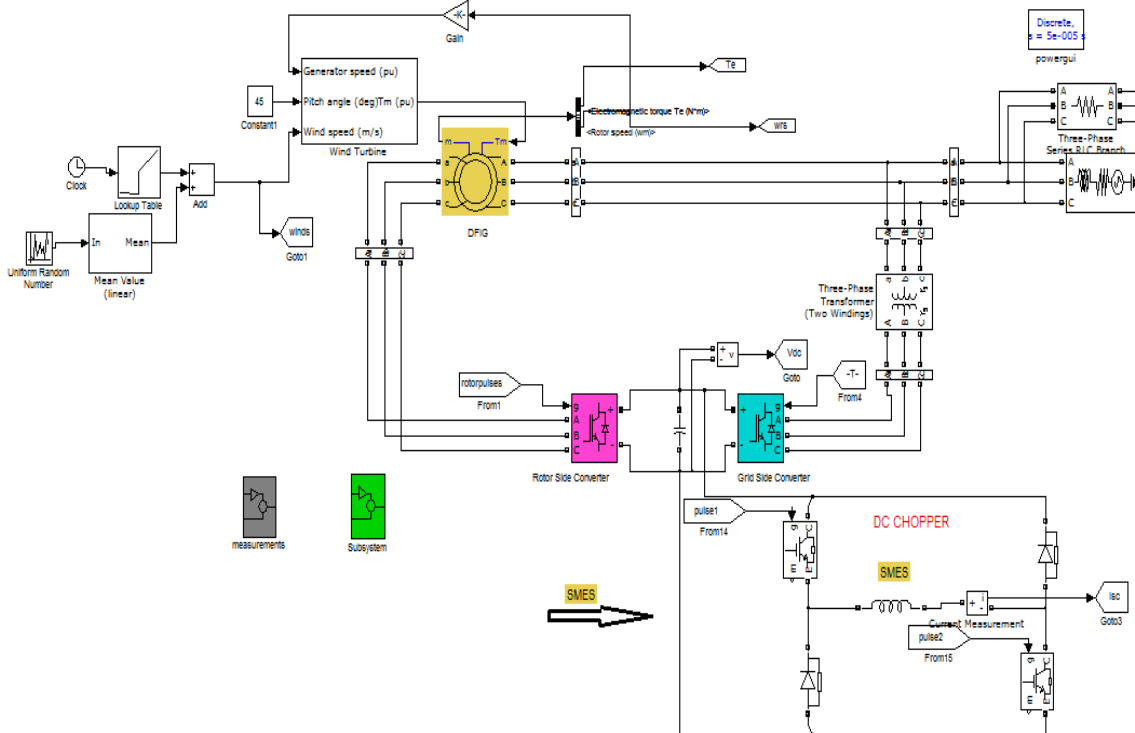

Figure 9. MAT Lab based circuit of DFIG Wind Power System with conventional controlled SEMS unit

a) Wave forms of DFIG

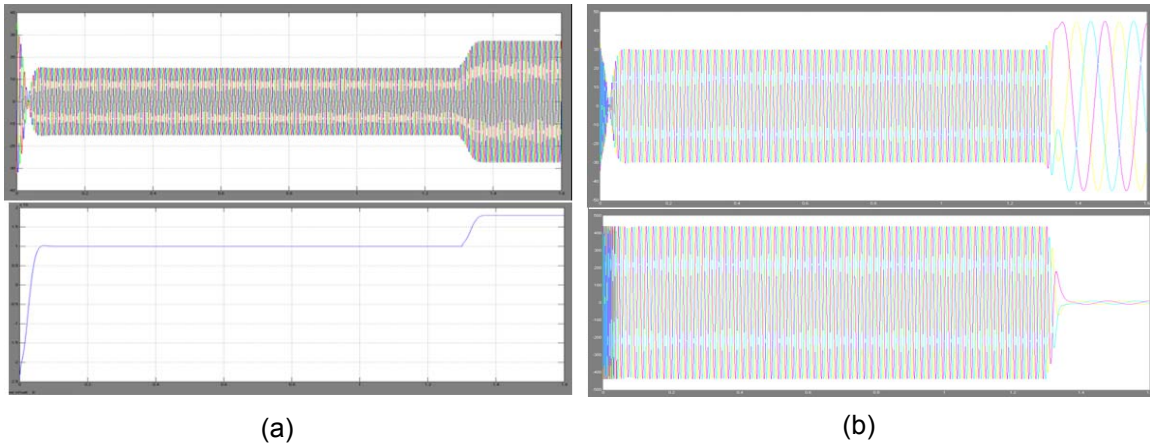

Figure 10. Stator and rotor voltage and currents; (a) stator voltage and currents, (b). rotor voltage and currents

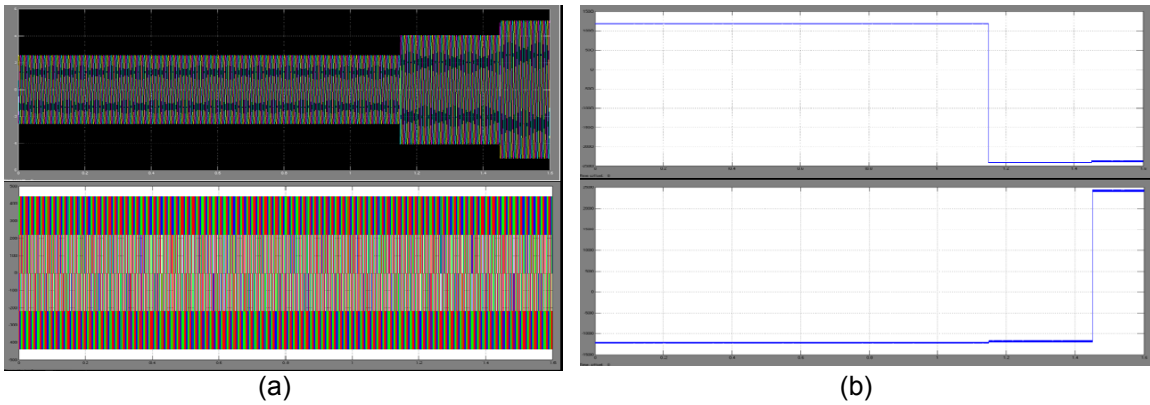
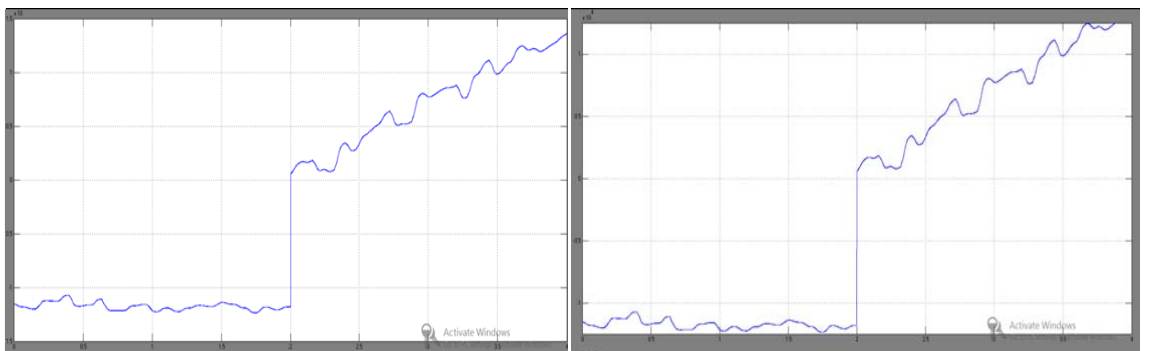

Figure 11. Wave forms; (a) Wave forms of ac side current & voltage, (b) Wave forms of ac side active power and reactive power;

b) Wind speed variation & output power on AC side



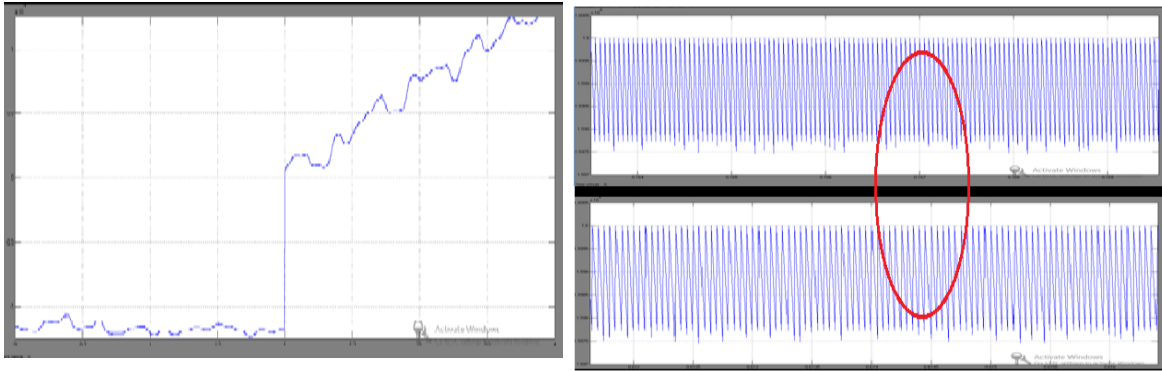

Figure 13. Wind Speed Variation Output At Power Coupling Point With Fuzzy Controller Based SMES

Ac side output power with SMES is not much distorted when input wind speed to the turbine is varies see above figures first one is wind speed variation second one is output power. If SMES is not presented distortions are more.

c) Fuzzy controller circuit used in smes unit

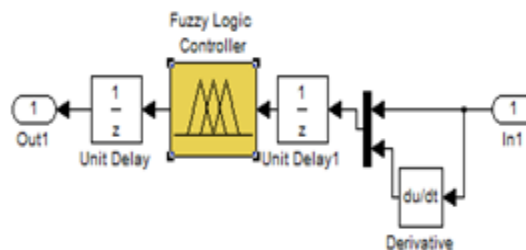

Figure 12. Fuzzy logic control

5. Conclusion

This paper proposes a study of the SMES based excitation system for DFIG used in wind power generation. The double level controller is designed to improve the stability and reliability of the wind power grid-connected system. To evaluate the dynamic response of the SMES based excitation system for DFIG, simulation tests are carried out using MATLAB SIMULINK. Smoothing the power fluctuation of DFIG when wind speed variation are observe hear with and without fuzzy control. The simulation results show that the excitation system can respond very quickly to the active and reactive power demands, and the power fluctuation of DFIG can be smoothen effectively. As to the fault ride-through control method, it will be discussed in the following work.

The wave distortions may be improved by implementing the control unit with Fuzzy-ANN technique.

References

- [1] A Abu-Siada, Member, IEEE, and Syed Islam, Senior Member, IEEE. "Application of SMES Unit in Improving the Performance of an AC/DC Power System". *IEEE transactions on sustainable energy*, 2011; 2(2).
- [2] Jing Shi, Yuejin Tang, Yajun Xia, Li Ren, and Jingdong Li. "SMES Based Excitation System for Doubly-Fed Induction Generator in Wind Power Application". *IEEE transactions on applied superconductivity*, 2011; 21(3), Digital Object Identifier 10.1109/TASC.2011.2105450.
- [3] S Muller, M Deicke, and RW De Doncker. "Doubly fed induction generator systems for wind turbines". *IEEE Trans. Industrial Appl. Magn.* 2002; 8(3): 26–33.

- [4] JB Ekanayake, L Holdsworth, X Wu, and N Jenkins. "Dynamic modeling of doubly fed induction generator wind turbines". *IEEE Trans. Power Syst.* 2003; 18(2): 803–809.
- [5] R Datta and VT Ranganathan. "Variable-speed wind power generation using doubly fed wound rotor induction machine comparison with alternative schemes". *IEEE Trans. Energy Convers.* 2002; 17(3): 414–421.
- [6] T Kinjo, T Senjyu, N Urasaki, and H Fujita. "Terminal-voltage and output-power regulation of wind-turbine generator by series and parallel compensation using SMES". in *IEE Proc. Gen., Transmiss. Distrib.* 2006; 153(3): 276–282.
- [7] MRI Sheikh, SM Muyeen, R Takahashi, T Murata, and J Tamura. "Transient stability enhancement of wind generator using superconducting magnetic energy storage unit". in *18th Int. Conf. Elect. Machines.* 2008: 1–6.
- [8] CJ Liu, CS Hu, X Li, Y Chen, M Chen, and DH Xu. "Applying SMES to smooth short-term power fluctuations in wind farms". in *IEEE 34th Annu. Conf. Ind. Electron.* 2008: 3352–3357.
- [9] MH Ali, J Tamura, and B Wu. "SMES strategy to minimize frequency fluctuations of wind generator system". in *IEEE 34th Annu. Conf. Ind. Electron.* 2008: 3382–3387.
- [10] J Shi, Y Tang, L Ren, J Li, and S Cheng. "Discretization-based decoupled state-feedback control for current source power conditioning system of SMES". *IEEE Trans. Power Deliv.* 2008; 23(4): 2097–2104.
- [11] M Liserre, R Cardenas, M Molinas, and J Rodriguez. "Overview of multi-MW wind turbines and wind parks". *IEEE Trans. Ind. Electron.* 2011; 58(4): 1081–1095.
- [12] J Hu, Y He, L Xu, and B Williams. "Improved control of DFIG systems during network unbalance using P IR current regulators". *IEEE Trans. Ind. Electron.* 2009; 56(2): 439–451.
- [13] E Muljadi, D Yildirim, T Batan, and C Butterfield. "Understanding the unbalanced-voltage problem in wind turbine generation". in *Conf. Rec. 34th IEEE IAS Annu. Meeting.* 1999; 2: 1359–1365.
- [14] MH Ali, B Wu, and RA Dougal. "An overview of SMES applications in power and energy systems". *IEEE Trans. Sustain. Energy.* 2010; 1(1): 38–47.