

## Effect of switched-capacitor on super-lift Luo converter

Hussein Abdulkhudhur Hussein<sup>1</sup>, Hassan Jassim Motlak<sup>2</sup>, Harith Nawfal Abdali Almusawi<sup>3</sup>

<sup>1</sup>Department of Computer Engineering Technology, Al Taff University College, Karbala, Iraq

<sup>2</sup>Department of Electrical Engineering, Babylon University, City of Hilla, Iraq

<sup>3</sup>Department of Biomedical Engineering, University of Warith Alanbiyaa, Karbala, Iraq

### Article Info

#### Article history:

Received Jan 8, 2022

Revised Jul 25, 2022

Accepted Aug 31, 2022

#### Keywords:

DC-DC converters

High gain converters

Input pulsating current

Super-lift Luo converter

### ABSTRACT

With the increasing need for solar energy and the need for DC-DC converters that are more efficient, smaller in size, less expensive, and faster in response, in this paper, we will modify the positive output super-lift Luo converter using a switched-capacitor cell. It consists of two capacitors that are charged in parallel and discharged in series to raise the output voltage, the use of capacitors in-stead of inductors increases the voltage, because capacitors are more efficient and have a smaller size than inductors and provide faster and smoother charging and discharging than inductors, so a capacitive cell has been used. The circuit was simulated using the physical security information management (PSIM) program. The current, voltage, and gain co-efficient waves were analyzed and the theoretical equations were proven. The circuit was also linked with the maximum power point tracker using the same program with a solar cell to get the most benefit from the solar energy using this type of converter.

*This is an open access article under the [CC BY-SA](https://creativecommons.org/licenses/by-sa/4.0/) license.*



### Corresponding Author:

Hussein Abdulkhudhur Hussein

Department of Computer Engineering Technology, Al Taff University College

Kerbala, Iraq

Email: husseinyasary66@gmail.com

## 1. INTRODUCTION

The need for DC-DC switching power converters is growing as more feasible alternatives to traditional carbon-producing energy sources emerge [1]-[4]. DC-DC power converters are compact and dependable power conversion systems [4]. The use of DC-DC converters in this application, on the other hand, adds new problems to the system [5], [6]. One of the key concerns is achieving a large step-up voltage gain while minimizing switch stress [7], [8].

Another important consideration with these converters is their great efficiency. Various DC-DC converters, such as interleaved converters, have been presented in the literature during the last few years to solve these issue [9], [10]. Soft-switching converters [11], [12] coupled-inductor structures [13], [14] and voltage multiplier converters [15], [16]. However, these structures are still in the development phase for answering the tough requirements.

One of the most important challenges of DC-DC converters used in solar energy systems is to obtain a high voltage gain at a small duty cycle to achieve high working efficiency [17], [18] reduce stress on the switch, reduce connection losses to a minimum, and reduce the effect of the input pulsating current that reduces the lifetime of the power source and reduce the system efficiency [19]. On the other hand, we should not depend on increasing the voltage gain on the improvement by using more inductors, because they are simply high in weight and high in cost [20]. Also, the use of many inductors leads to undesirable electromagnetic interference. In this article, it is proposed to develop a positive-output Luo converter using a simple structure consisting of two capacitors and three diodes in a three-terminal cell that is placed in the

place of the first capacitor in the traditional Luo converter to achieve high gain and efficiency without the need for any additional inductors and operate it as part of the solar energy system and to simulate the system suggested by program physical security information management (PSIM). Figure 1 shows the complete system of PV panel and modified converter with MPPT controller.

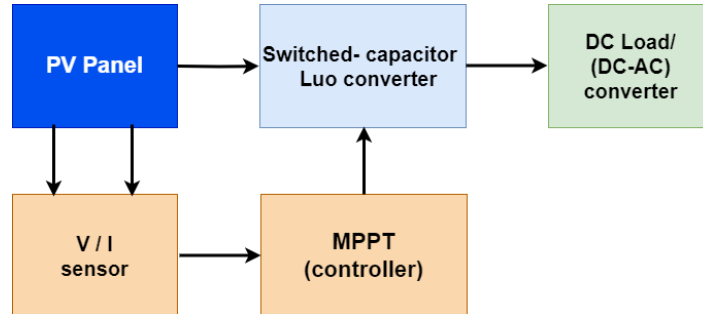

Figure 1. Block diagram of the proposed system

**2. ELEMENTARY POSITIVE OUTPUT SUPER-LIFT LUO CONVERTER**

PV systems employ DC-DC step-up converters to control the voltage generated by PV modules and to raise the module voltage [21]-[23]. One switch (S), one inductor (L), capacitors (C1&C2), and two diodes make up the positive output super-lift Luo converter (POS LC). Figure 2 depicts the POS LC circuit architecture, as well as its modeling (1) (on-state) and (2) (off-state) for displaying the output voltage gain [24]:

$$V_{in} = VL = V_{c1} = L \Delta i / dt \tag{1}$$

$$\Delta i = VL \frac{(1-D)T}{L} = V_o - 2V_{in} \frac{(1-D)T}{L} \tag{2}$$

$$G = \frac{V_o}{v_{in}} = \frac{2-D}{1-D} \tag{3}$$

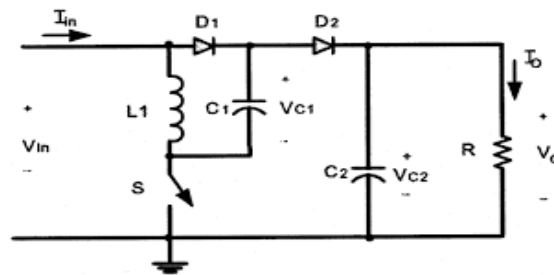

Figure 2. Elementary circuit of POS LC [25]

**3. MODIFICATION OF POS LC USING SWITCHED-CAPACITOR CELL**

The update of the POS LC converter, as shown in Figure 3, it is different from the elementary by using a capacitor switching cell. The difference in the cell is the replacement (C1) by cell constructed from three capacitors (C1 and C2). The proposed converter work as follows: at the switch-on, the passive element (inductors and the three capacitors) will be charged, the path of a current charge become as follows: diode (D2) is a reverse bias, and the diode (D1) in the forward bias, the capacitor (C1), capacitor (C2), capacitor (C3), and inductor (L1) in parallel connection.

At the switch-off state, the diode (D1&D2) in the forward bias, the discharge path of current C1, C2, C3, and L1 in series connection to the capacitor (Co) and then to the load. When the circuit is at the steady-state, notice that the diode (D2) has a second function, which is to prevent the charge stored in the capacitor (Co) from reversing to the circuit elements. The main reason for increasing voltages more than an elementary circuit is that each element (L1, C1, C2, and C3) stores energy as much as the source energy. Then the energy

combined is pumped at the same time into a load. Figure 3 shows the modified converter and on-off states configuration.

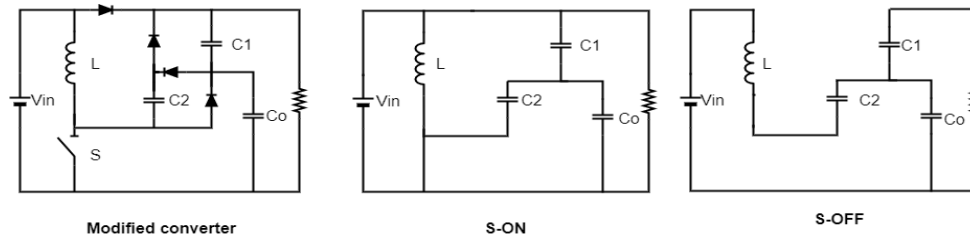

Figure 3. Modified positive output super-lift Luo converter

**4. MATHEMATICAL MODELLING**

Mode 1: (0~DT): switch ON,

$$v_{in} = v_L \tag{4}$$

$$v_{C1} = v_{Co} \tag{5}$$

$$v_L = v_{C1} + v_{C2} \tag{6}$$

C1 and C2 must be equal value to reduce ripple. According to (3) it out the same result at the switch-on state. Mode 2: (DT~(1-D) T): switch OFF,

$$v_o = v_{C1} + v_{C2} \tag{7}$$

$$v_{C1} = V_{C2} \tag{8}$$

The average inductor voltage for a period of time is:

$$V_{in}D + (V_i - V_{Co})(1 - D) = 0 \tag{9}$$

$$V_{in} = V_{Co} - V_{Co} D \tag{10}$$

$$V_{Co} = \frac{1}{1-D} V_{in} \tag{11}$$

Sub (10) in (11) we get,

$$V_o = 2 V_{Co} \tag{12}$$

Now sub (10) in (12),

$$\frac{V_o}{v_{in}} = \frac{2}{1-D} \tag{13}$$

Finally, (13) of output voltage in the modify circuit and we notice that the proposed converter. It gives a higher lift rate to voltage according to the original circuit.

Figure 3 shows the circuit at switch-off with the current path and supply a load. Figure 4 shows the elementary and modified converters implemented in PSIM. Table 1 shows the values of all parameters ant units.

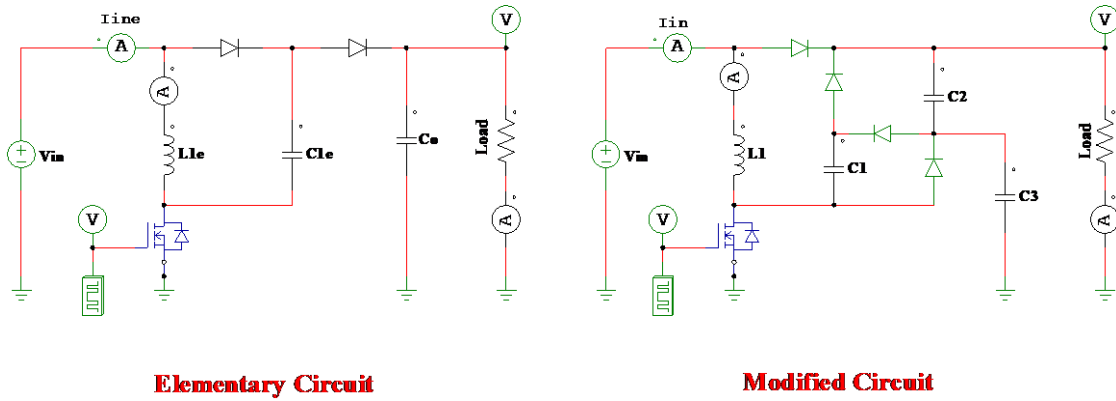

Figure 4. Elementary and modified converters implemented in PSIM

Table 1. Parameters of the converters

Parameter name	Symbol	Value	Unit
Inductors	(LI, LLe)	1	mH
Load resistance	R	50	Ω
Capacitors	(C1,2,3,e,o)	220	uH
Switching frequency	f	60	kΩ

**5. MATHEMATICAL MODELLING AT DISCONTINUOUS CONDUCTION MODE**

Mode 1: (0 DT): switch-ON,

$$v_{in} = v_L \tag{14}$$

$$\Delta i = \frac{v_{in} D T}{L} \tag{15}$$

Mode 2: (DT~(1-D) T): switch-OFF,

$$V_{in} D + (V_i - V_{co})(1 - D) = 0 \tag{16}$$

$$(1 - D) = \frac{-V_{in} D}{V_i - V_{co}} \tag{17}$$

$$I_{CO} = \frac{1}{2} D' \Delta i_L - I_o \tag{18}$$

At steady state  $I_{CO} = 0$ ,

$$I_o = \frac{1}{2} D' \Delta i_L \tag{19}$$

$$\frac{1}{2} \frac{V_{in} D}{V_i - V_{co}} * \frac{v_{in} D T}{L} = \frac{V_o}{R} \tag{20}$$

By simplify (20) we get:

$$\tau = \frac{D^2}{2((\frac{1+D}{1-D})^2 - 1)} \tag{21}$$

Note: to minimize ripple in circuit that involve a cell, the capacitors values of (C1) and (C2) must be equal value when designing. Because the ripple is the result of a switching process that occurs on inductance or capacitor. When adding a cell whose capacitors are equal in values, this increases the value of the capacitance impedance and thus prevents ripple.

Plotting equation ( $\tau$ ) with duty cycle (D) producing a Figure 5. From the chart of boundary condition continuous conduction mode & discontinuous conduction mode (CCM&DCM), can note area of working of a converter. We note area DCM decreases with an increasing duty cycle (D).

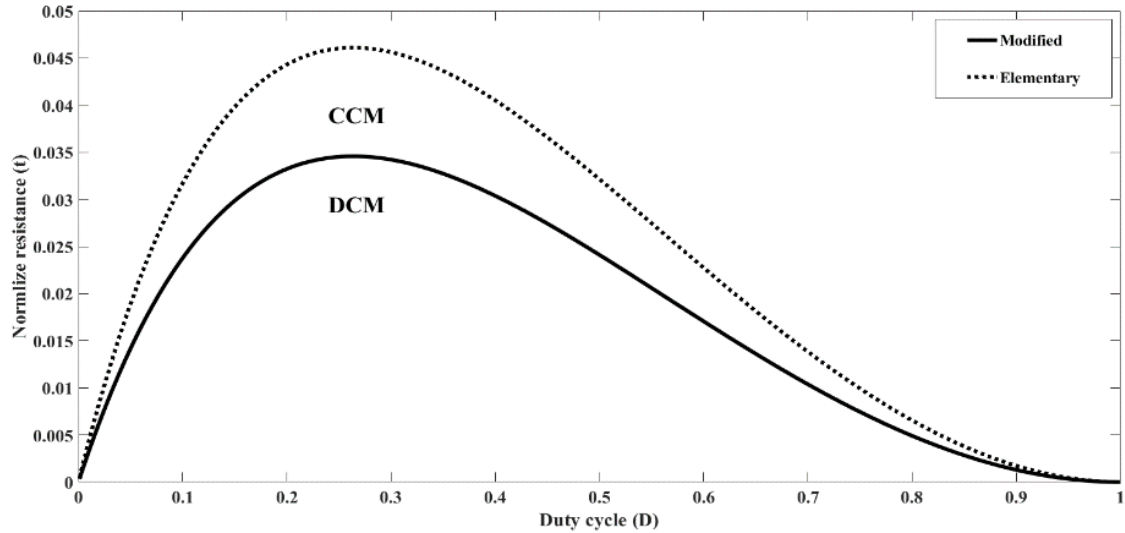

Figure 5. Boundary conditions between CCM and DCM of modified converter

**6. RESULTS AND DISCUSSION**

Figure 6 shows the ratio of the output voltage at (13) with respect to a duty cycle at the proposed converter. Increasing the duty cycle leads to lifting voltage. In Figure 7, it is very clear that at an input voltage of 10 V, the output voltage is 30 V at the traditional converter and 40 V at the proposed converter at (D=0.5). Figure 8 shows the input current of the elementary converter ( $I_{in}$ ) and the input current of the proposed converter ( $I_{in}$ ), the continuous (low ripple) input current of the proposed converter is too obvious, and this property make the modified Luo converter is much better than the elementary Luo converter because the input pulsating current reduce the efficiency and the life time of the power source. Figure 9 shows the maximum power point tracker controller of the converter since the ( $P_{max}$ ) is the maximum power the PV panel could generate it at 1,000 and 800  $w/m^2$ , while the ( $P_O$ ) is the real output power of the panel coming to converter.

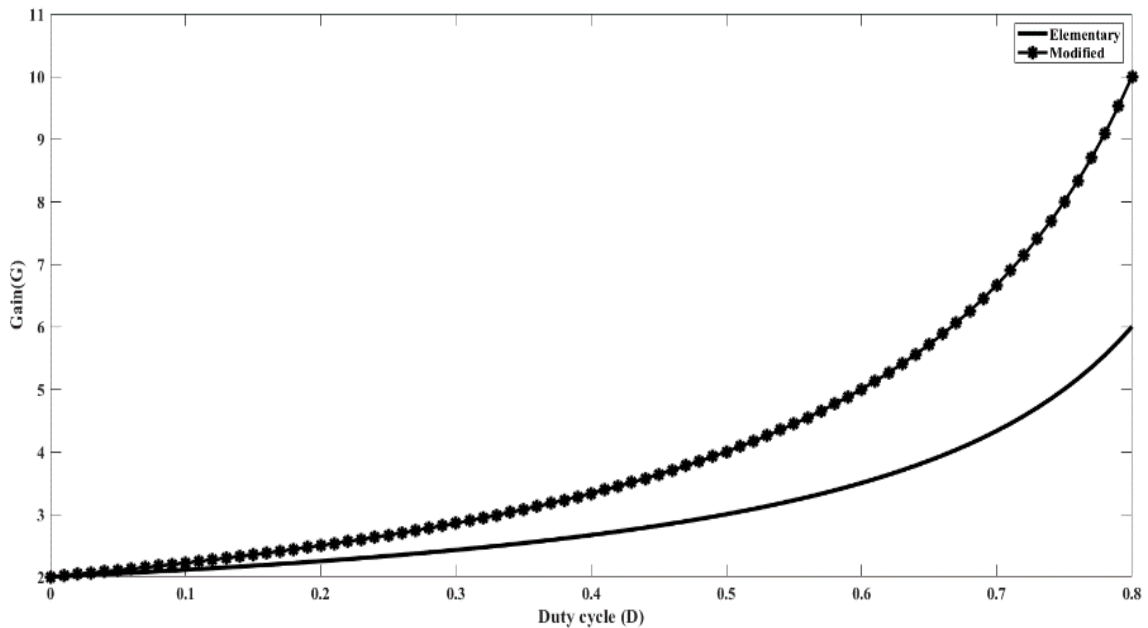

Figure 6. Relationship between gain and duty cycle

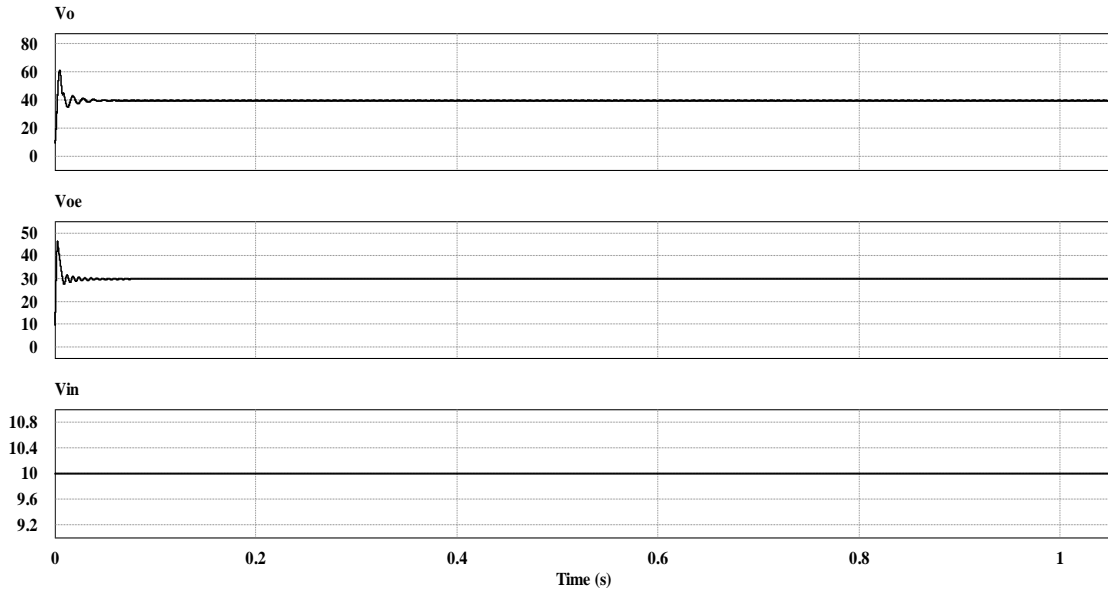

Figure 7. Input and output voltages of the elementary (Voe) and modified (Vo) converters

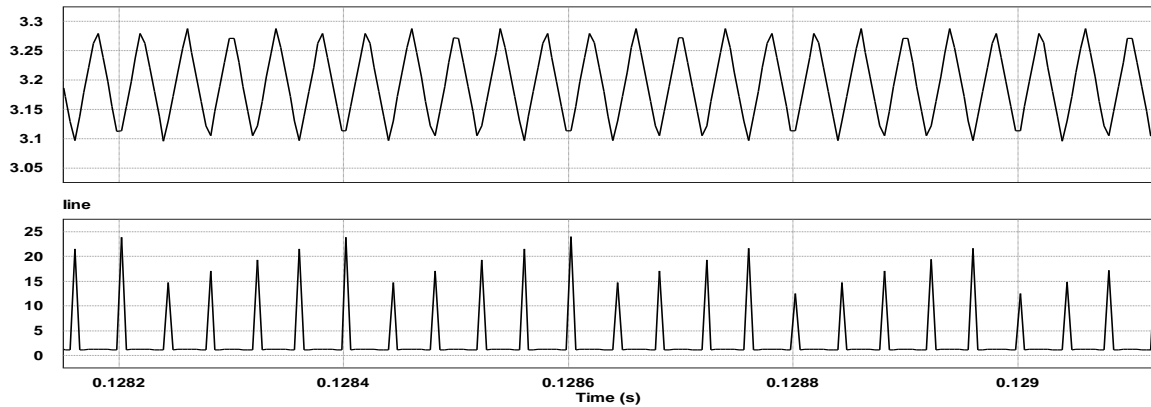

Figure 8. Input current for both elementary and modified converter

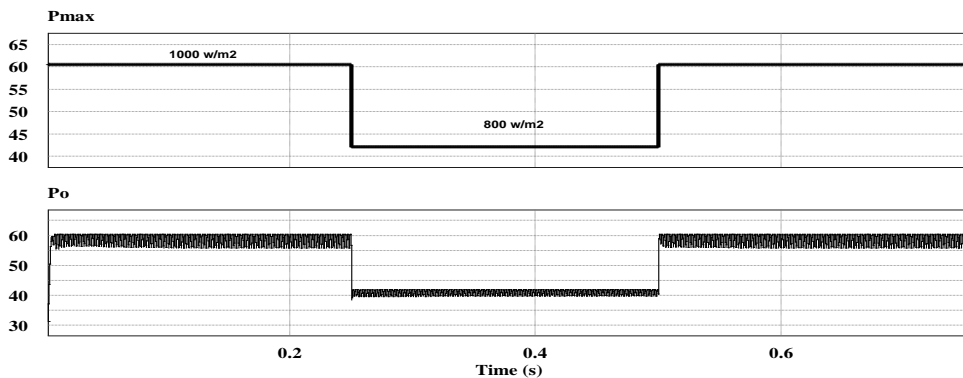

Figure 9. Maximum power point of the PV panel and output power of the panel

## 7. CONCLUSION



A new modification of the Luo converter has been presented in this article. This converter has been modeled and simulated using PSIM program and the simulation results satisfied the theoretical results. When

DC-DC Luo converter with a higher voltage gain than the traditional Luo converter is needed in the photovoltaic power system, this proposed Luo converter is used. It has the ability to raise a higher voltage, so it reduces stress on the switch. It does not depend on more inductors, as in many of the proposed solutions, as it reduces electromagnetic interference and reduces weight and cost (depending on the capacitors in increasing the voltage). Most important of all, the proposed Luo converter can be used in applications that require a continuous input current. It eliminates the input pulsating current significantly.



## REFERENCES

- [1] J. Darvill, "Conceptual development of a novel digital controller for optimised operation of a hybrid renewable energy system," Ph.D. dissertation, Anglia Ruskin University, 2018.
- [2] F. Ahmad, "Analysis of microgrids for plug-in hybrid electric vehicles charging stations," Ph.D. dissertation, Dept. Elect. Eng., Aligarh Muslim University Aligarh, India, 2019.
- [3] V. Birss, E. El Sawy, S. Ketabi, P. Keyvanfar, X. Li, and J. Young, "Electrochemical energy production using fuel cell technologies," *Handbook of Industrial Chemistry and Biotechnology*, 2017, pp. 1729-1779, doi: 10.1007/978-3-319-52287-6\_32.
- [4] D. Angulo-García, F. Angulo, and J. G. Muñoz, "DC-DC zeta power converter: Ramp compensation control design and stability analysis" *Applied Sciences*, vol. 11, no. 13, pp. 1-18, 2021, doi: 10.3390/app11135946.
- [5] Z. Rehman, I. Al-Bahadly, and S. Mukhopadhyay, "Multiinput DC-DC converters in renewable energy applications—an overview," *Renewable and Sustainable Energy Reviews*, vol. 41, pp. 521-539, Jan. 2015, doi: 10.1016/j.rser.2014.08.033.
- [6] N. Vosoughi, M. Abbasi, E. Abbasi, and M. Sabahi, "A zeta-based switched-capacitor DC-DC converter topology," *International Journal of Circuit Theory and Applications*, vol. 47, no. 8, pp. 1-21, 2019, doi: 10.1002/cta.2647.
- [7] R. Madeira and N. Paulino, "Analysis and implementation of a power management unit with a multiratio switched capacitor DC-DC converter for a supercapacitor power supply," *International Journal of Circuit Theory and Applications*, vol. 44, no. 11, pp. 2018-2034, Mar. 2016, doi: 10.1002/cta.2209.
- [8] F. Shang, G. Niu, and M. Krishnamurthy, "Design and analysis of a high-voltage-gain step-up resonant DC-DC converter for transportation applications," in *IEEE Transactions on Transportation Electrification*, vol. 3, no. 1, pp. 157-167, 2017, doi: 10.1109/TTE.2017.2656145.
- [9] Y. P. Siwakoti and F. Blaabjerg, "Single switch nonisolated ultra-step-up DC-DC converter with an integrated coupled inductor for high boost applications," in *IEEE Transactions on Power Electronics*, vol. 32, no. 11, pp. 8544-8558, Nov. 2017, doi: 10.1109/TPEL.2016.2646382.
- [10] O. Hegazy, J. V. Mierlo, and P. Lataire, "Analysis, modeling, and implementation of a multidevice interleaved DC/DC converter for fuel cell hybrid electric vehicles," in *IEEE Transactions on Power Electronics*, vol. 27, no. 11, pp. 4445-4458, 2012, doi: 10.1109/TPEL.2012.2183148.
- [11] R. Rahimi, M. Farhadi, G. R. Moradi, B. Farhangi, and S. Farhangi, "Filter-clamped two-level three-phase transformerless grid-connected photovoltaic inverter for leakage current reduction," *2020 IEEE Kansas Power and Energy Conference (KPEC)*, 2020, pp. 1-6, doi: 10.1109/KPEC47870.2020.9167569.
- [12] H. Seong, H. Kim, K. Park, G. Moon and M. Youn, "High step-up DC-DC converters using zero-voltage switching boost integration technique and light-load frequency modulation control," in *IEEE Transactions on Power Electronics*, vol. 27, no. 3, pp. 1383-1400, Mar. 2012, doi: 10.1109/TPEL.2011.2162966.
- [13] Z. Ding, C. Yang, Z. Zhang, C. Wang, and S. Xie, "A novel soft-switching multiport bidirectional DC-DC converter for hybrid energy storage system," in *IEEE Transactions on Power Electronics*, vol. 29, no. 4, pp. 1595-1609, Apr. 2014, doi: 10.1109/TPEL.2013.2264596.
- [14] H. Liu and F. Li, "A novel high step-up converter with a quasi-active switched-inductor structure for renewable energy systems," in *IEEE Transactions on Power Electronics*, vol. 31, no. 7, pp. 5030-5039, Jul. 2016, doi: 10.1109/TPEL.2015.2480115.
- [15] M. Abbasi, E. Abbasi, B. Tousi, and G. B. Gharehpetian, "A zero-current switching switched-capacitor DC-DC converter with reduction in cost, complexity, and size," *International Journal of Circuit Theory and Applications*, vol. 47, no. 10, pp. 1-15, 2019, doi: 10.1002/cta.2678.
- [16] E. Babaei and O. Abbasi, "Structure for multi-input multi-output DC-DC boost converter," *IET Power Electronics*, vol. 9, no. 1, pp. 9-19, Jan. 2016, doi: 10.1049/iet-pel.2014.0985.
- [17] T. Nouri, S. H. Hosseini, E. Babaei, and J. Ebrahimi, "Generalised transformerless ultra step-up DC-DC converter with reduced voltage stress on semiconductors," *IET Power Electronics*, vol. 7, no. 11, pp. 2791-2805, Nov. 2014, doi: 10.1049/iet-pel.2013.0933.
- [18] M. Das and V. Agarwal, "Design and analysis of a high-efficiency DC-DC converter with soft switching capability for renewable energy applications requiring high voltage gain," in *IEEE Transactions on Industrial Electronics*, vol. 63, no. 5, pp. 2936-2944, May 2016, doi: 10.1109/TIE.2016.2515565.
- [19] A. Tomaszuk and A. Krupa, "High efficiency high step-up DC/DC converters-a review," *Bulletin of the Polish Academy of Sciences: Technical Sciences*, vol. 59, no. 4, pp. 475-483, Dec. 2011, doi: 10.2478/v10175-011-0059-1.
- [20] A. Elkhateb, N. A. Rahim, J. Selvaraj, and B. W. Williams, "The effect of input current ripple on the photovoltaic panel efficiency," *2013 IEEE Conference on Clean Energy and Technology (CEAT)*, 2013, pp. 478-481, doi: 10.1109/CEAT.2013.6775680.
- [21] R. Kumar, B. Sahu, C. Shiva, and B. Rajender "A control topology for frequency regulation capability in a grid integrated PV system," *Archives of Electrical Engineering*, vol. 69, no. 2, pp. 389-401, 2020, doi: 10.24425/ae.2020.133033.
- [22] Y. Jiang, J. A. A. Qahouq, and I. Batarseh, "Improved solar PV cell MATLAB simulation model and comparison," *2010 IEEE International Symposium on Circuits and Systems (ISCAS)*, 2010, pp. 2770-2773, doi: 10.1109/ISCAS.2010.5537014.
- [23] H. K. Khalil, S. S. Hreshee, and H. J. Motlak, "Design and implementation of photovoltaic system based on super-lift LUO converter," *Journal of Physics: Conference Series*, vol. 1530, no. 1, p. 012013, May 2020, doi: 10.1088/1742-6596/1530/1/012013.
- [24] M. Forouzesh, Y. P. Siwakoti, S. A. Gorji, F. Blaabjerg, and B. Lehman, "Step-up DC-DC converters: a comprehensive review of voltage-boosting techniques, topologies, and applications," in *IEEE Transactions on Power Electronics*, vol. 32, no. 12, pp. 9143-9178, Dec. 2017, doi: 10.1109/TPEL.2017.2652318.
- [25] F. L. Luo and Y. F. Ye, *Essential DC/DC converters*, Boca Raton, Florida: CRC Press, 2018.



**BIOGRAPHIES OF AUTHORS**

**Hussein Abdulkhudhur Hussein**    received the B.Sc. in Electrical Engineering from the University of Babylon in 2015 interested in photovoltaic systems, converters, and industrial engineering work. He worked in many engineering factories, received his master's degree in industrial electronics in 2022, and is now working as a lecturer at Al taff University College. He can be contacted at email: hussein.radi@student.uobabylon.edu.iq and husseinyasary66@gmail.com.



**Hassan Jassim Motlak**    he was born in baghdad on 1966. He received B.Sc. in Electrical Engineering from University of Technology on 1991. He got M.Sc. in solid state electronics from University of Technology on 2001. He got Ph.D. in Electronics and Communication Engineering on 2009 From JMI, New Delhi, India. His interested field in design of analog signal processing devices. He can be contacted at email: hssn\_jasim@yahoo.com.



**Harith Nawfal Abdali Almusawi**    He born in Iraq, Karbala City, Al-Hyndia. He received a B.Sc. from Babylon University in General Electrical Engineering 2015. The M.Sc. is in Electronics and Communications field from the University of Babylon, Iraq 2019 and now on the way to finish Ph.D. degree in Electronics and Communications field from the University of Babylon, Iraq. Since 2021, he has been an Assistant Lecturer with the Department of Biomedical Engineering, University of Warith AL-Anbiyaa. The fields that the author interested are, renewable energy, electronic communication, power system, industrial electronic, antennas, and digital signal processing. Also, until know, he has many articles in these fields. He can be contacted at email: harith.na@g.uowa.edu.iq.